

4

3

2

1

GENERAL NOTES:

1. MATERIAL: **ALUMINUM, 7075-T651**
2. SPECIAL FINISH: **NONE**
3. SURFACE ROUGHNESS (UNLESS SPECIFIED OTHERWISE): **32 Ra** (AVERAGE MICRO-INCHES)
4. INTERPRET DIMENSIONS AND TOLERANCES PER ASME Y14.5M-1994
5. DEBURR AND BREAK ALL SHARP EDGES, MAX 0.010" (UNLESS SPECIFIED OTHERWISE)
6. PARTS ARE TO BE CLEAN AND FREE OF OIL, GREASE, AND OTHER CONTAMINANTS
7. DIMENSIONS INCLUDE ANODIZING, ELECTROPLATING, AND CHEMICALLY APPLIED FINISHES IF APPLICABLE

| REVISION HISTORY |     |                              |            |              |
|------------------|-----|------------------------------|------------|--------------|
| ZONE             | REV | DESCRIPTION                  | DATE       | APPROVED     |
|                  | -   | INITIAL RELEASE              | 2021/02/15 | hhmi\arnoldj |
|                  | A   | REDUCE DOVETAIL HEIGHT       | 7/7/2021   | HHMI\arnoldj |
|                  | B   | SWITCH TO 45 DEGREE DOVETAIL | 9/20/2021  | HHMI\arnoldj |

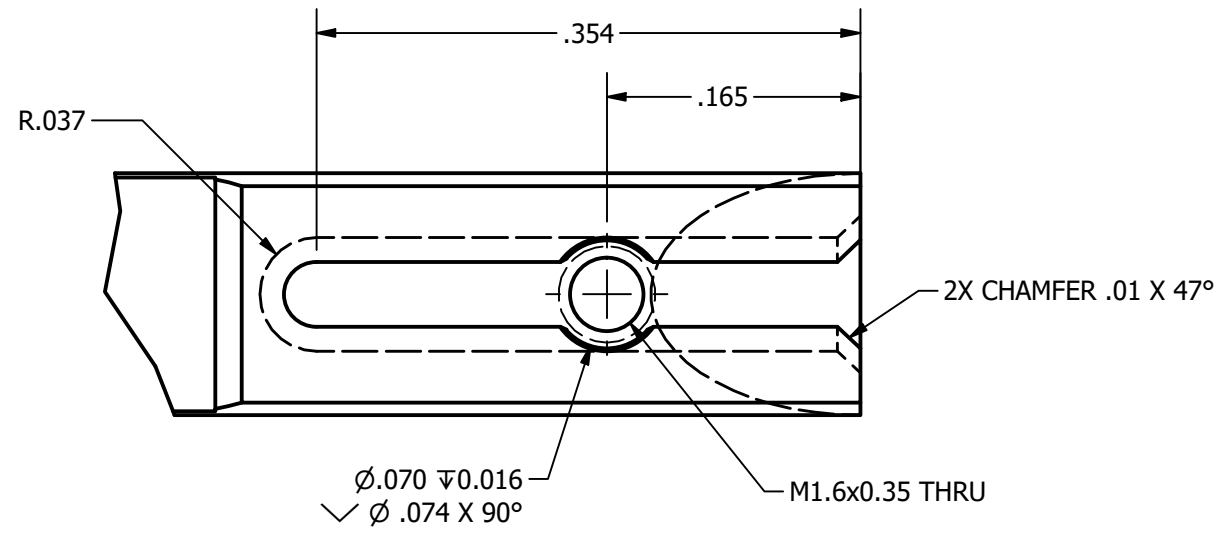

DETAIL B

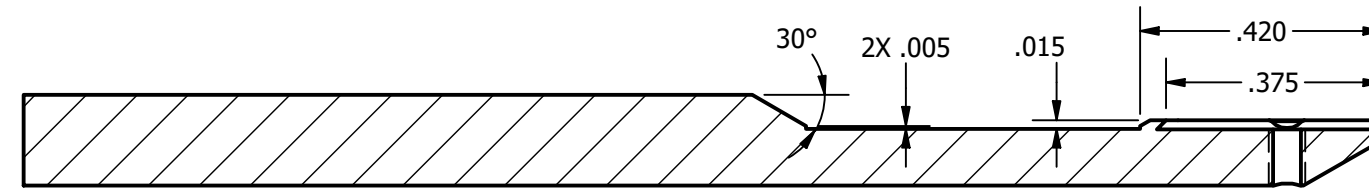

DETAIL D

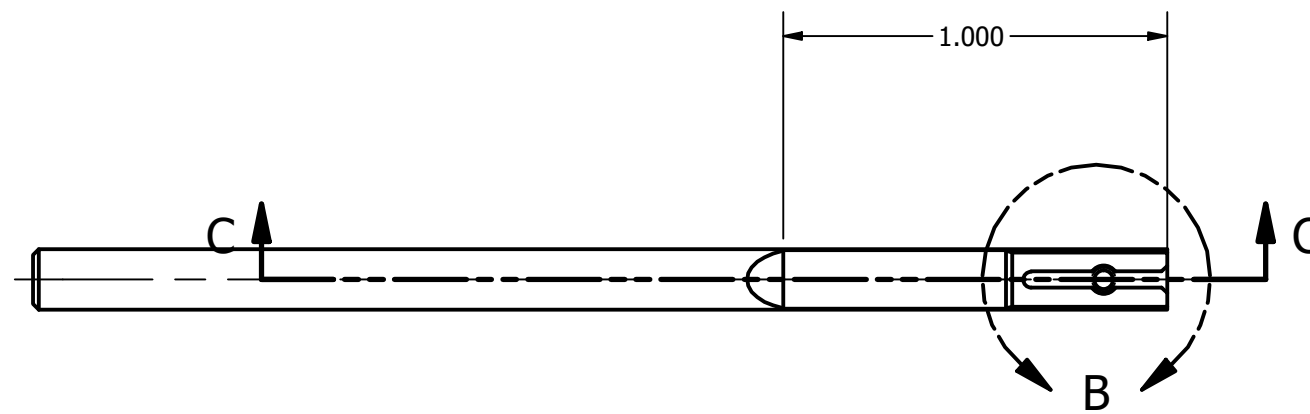
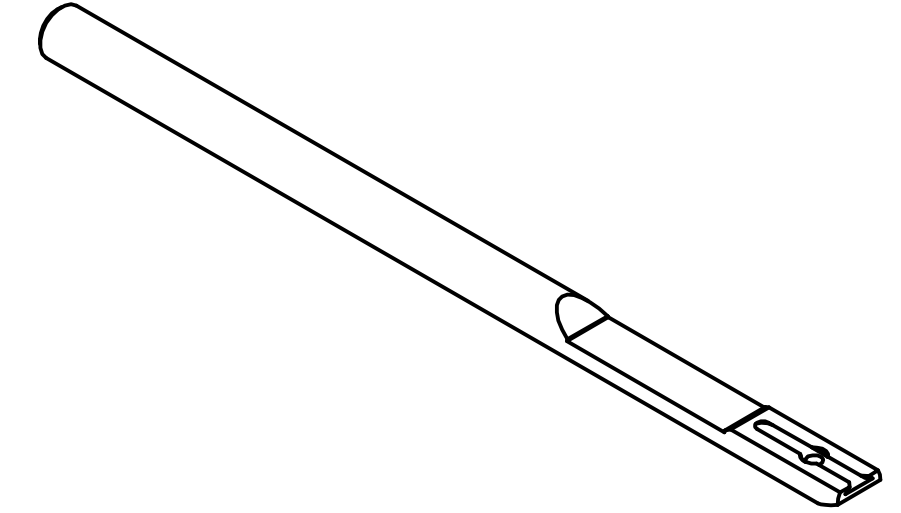

SECTION C-C

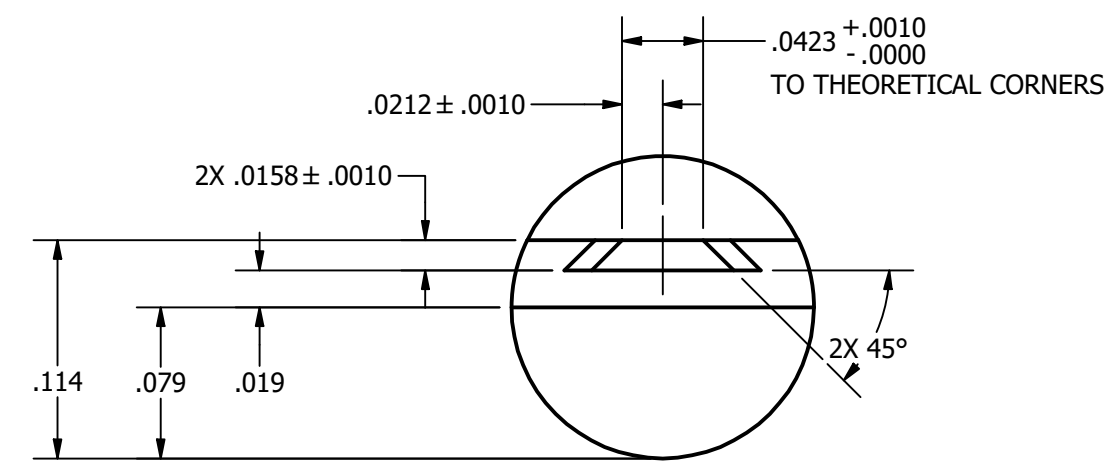

DETAIL A

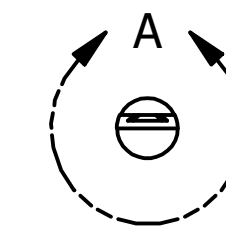
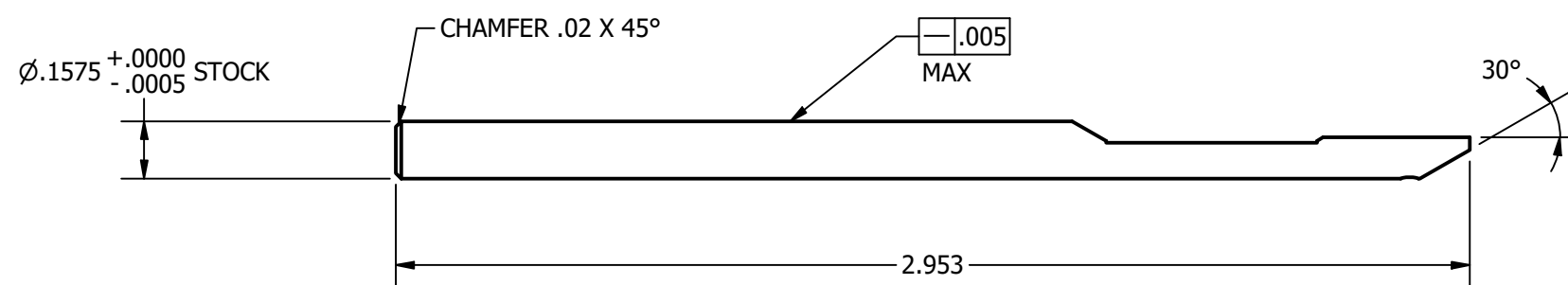

NOTICE:  
 INFORMATION CONTAINED IN THIS DOCUMENT OR ANY REPRODUCTION THEREOF, IS PROPRIETARY INFORMATION AND PROPERTY OF HOWARD HUGHES MEDICAL INSTITUTE. IT SHALL NOT BE DISCLOSED, COPIED, DUPLICATED OR USED FOR MANUFACTURE, PRODUCTION OR PROCUREMENT, WITHOUT THE EXPRESS WRITTEN PERMISSION OF HOWARD HUGHES MEDICAL INSTITUTE.

(UNLESS SPECIFIED OTHERWISE)  
 PRIMARY UNITS: INCHES  
 [SECONDARY UNITS]: MILLIMETERS

PRIMARY TOLERANCES:  
 X.X ± 0.020  
 X.XX ± 0.010  
 X.XXX ± 0.005  
 X.XXXX ± 0.0005  
 ANGULAR ± 0.5 DEG

- DO NOT SCALE DRAWING -  
 THIRD ANGLE PROJECTION:

|  |                        |                 |                 |
|--|------------------------|-----------------|-----------------|
| Howard Hughes Medical Institute                            |                        | Research Campus |                 |
| <b>NEUROPIXELS GEN 2 DOVE TAIL PROBE HOLDER_NARROW.ipt</b> |                        |                 |                 |
| SIZE<br>C  | PART NUMBER<br>J009776 | REV<br>B        | SHEET<br>1 OF 1 |

4

3

2

1